

# CM-CP 2

IN-LINE PUMPS





### TECHNICAL DATA

**Operating range:** up to 36 m<sup>3</sup>/h with head up to 50 m.  
**Type of pumped liquid:** clean, free of solids and abrasives, non-viscous, non-aggressive, non-crystallised  
**Glycol percentage (maximum):** 50%  
**Liquid temperature range:** from -15 °C to +140 °C  
**Maximum ambient temperature:** +50 °C  
**Maximum operating pressure:** 16 Bar (1600 kPa)  
**Flanging:** PN10 - PN16  
**Protection:** IP 55  
**Insulation:** class F  
**Impeller material:** Cast iron or technopolymer  
**Three phase power input:** 3x230 V 50 Hz / 3x400 V 50 Hz  
**max rpm:** 2910  
**Type of installation:** Fixed in horizontal or vertical position with motor in up position. Only in vertical position for motor from 7,5 kW.

### APPLICATIONS

In-line pumps for use in commercial building service, designed for the recirculation of water in air conditioning and heating systems even in the presence of solar collectors. Available in twin version (models with letter D).

### CONSTRUCTION FEATURES OF THE PUMP

Suction and delivery ports in line and flanged PN 10 or PN 16 with threaded connectors for control pressure gauges. Pump body and motor support in cast iron. Impeller in cast iron or technopolymer depending on the model. Standard mechanical seal according to DIN 24960 in silicon carbide / silicon carbide with O-rings in EPDM.

### CONSTRUCTION FEATURES OF THE MOTOR

Air-cooled three-phase asynchronous motor with two poles. Motor shaft in stainless steel. Electrical protection by the user.

### MATERIALS

N.	PARTS	MATERIALS
1	PUMP BODY	CAST IRON EN G.JL250 UNI EN 1561
2	SUPPORT	CAST IRON EN G.JL250 UNI EN 1561
3	IMPELLER	CAST IRON EN G.JL200 UNI EN 1561 AND ULTRASON E 2010
4	SHAFT WITH ROTOR	AISI 316 + C10
5	MECHANICAL SEAL	SPRING AISI 316 - ESIC / ESIC - EPDM
6	O-RING	EPDM

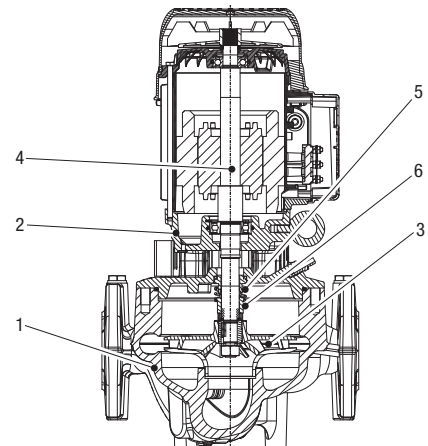

### Denominations: (example)

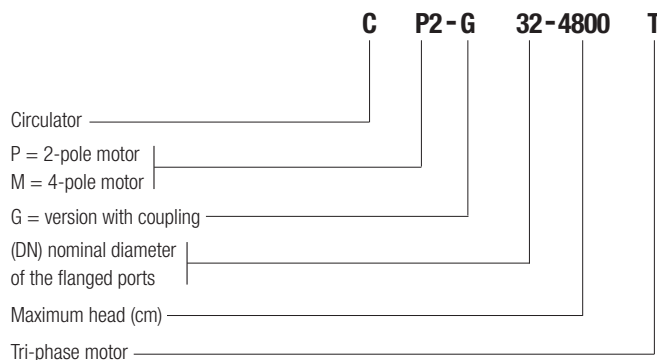

### SELECTION TABLE - CM 2

MODEL	HYDRAULIC DATA																			
	Q=m <sup>3</sup> /h	0	2	4	6	8	10	12	14	16	18	20	22	24	26	28	30	32	34	36
	Q=l/min	0	33	67	100	133	167	200	233	267	300	333	367	400	433	467	500	533	567	600
CM 2 32-450 T	H (mt)	4,4	4,3	4,1	3,8	3,5	3,0	2,4	1,7	0,9										
CM 2 32-600 T		6,0	5,9	5,7	5,4	4,9	4,3	3,6	2,8	1,9	1,0									
CM 2 32-800 T		7,9	7,7	7,5	7,1	6,6	6	5,3	4,5	3,6	2,6	1,5	0,3							
CM 2 32-1200 T		12	12	12	11	11	10	9,5	8,6	7,6	6,4	5,1	3,7	2,1	0,4					

### SELECTION TABLE - CP 2

MODEL	HYDRAULIC DATA																				
	Q=m <sup>3</sup> /h	0	2	4	6	8	10	12	14	16	18	20	22	24	26	28	30	32	34	36	
	Q=l/min	0	33	67	100	133	167	200	233	267	300	333	367	400	433	467	500	533	567	600	
CP 2 32-550 T	H (mt)	5,5	5,5	5,2	4,9	4,4	3,9	3,3	2,7	2,2	1,7	1,4									
CP 2 32-750 T		7,4	7,2	6,9	6,6	6,2	5,6	5,1	4,4	3,7	2,8	1,9	1,0								
CP 2 32-1100 T		10,6	10,4	10,1	9,7	9,3	8,7	8,1	7,4	6,5	5,6	4,5	3,3	2,0	0,5						
CP 2 32-1400 T		14,3	14,0	13,7	13,3	12,8	12,3	11,7	10,9	10,1	9,2	8,2	7,1	5,8	4,4	2,9	1,3				
CP 2 32-1800 T		17,8	17,7	17,4	17,0	16,6	16,1	15,5	14,7	13,9	13,0	12,0	10,9	9,7	8,3	6,9	5,3	3,6	1,8		
CP 2 32 2200 T		21,9	21,8	21,6	21,2	20,8	20,2	19,5	18,7	17,7	16,7	15,5	14,1	12,7	11,1	9,3	7,4	5,4	3,2	0,8	
CP 2 32-2100 T		21,5	20,9	19,9	18,4	16,4	13,8	10,6	6,8	2,1											
CP 2 32-2700 T		26,7	26,5	26,3	25,9	25,4	24,9	24,3	23,7	23,0	22,3	21,5	20,7	19,9	19,1						
CP 2 32-3600 T		36,4	36,7	36,8	36,6	36,3	35,7	35,0	34,2	33,3	32,2	31,1	29,9	28,8	27,6	26,4	25,2	24,1	23,1	22,2	
CP 2 32-4000 T		40,3	40,6	40,7	40,6	40,2	39,7	39,0	38,2	37,3	36,2	35,1	33,9	32,6	31,2	29,9	28,5	27,2	25,8	24,5	
CP 2-G 32-4800 T		49,1	49,0	48,9	48,7	48,4	48,0	47,6	47,0	46,3	45,5	44,6	43,5	42,3	41,0	39,6	37,9	36,2	34,3	32,2	

## CM 2 - IN-LINE PUMPS FOR CIRCULATION SYSTEMS

Liquid temperature range: from -15°C to +140°C - Maximum operating pressure: 16 bar (1600 kPa)

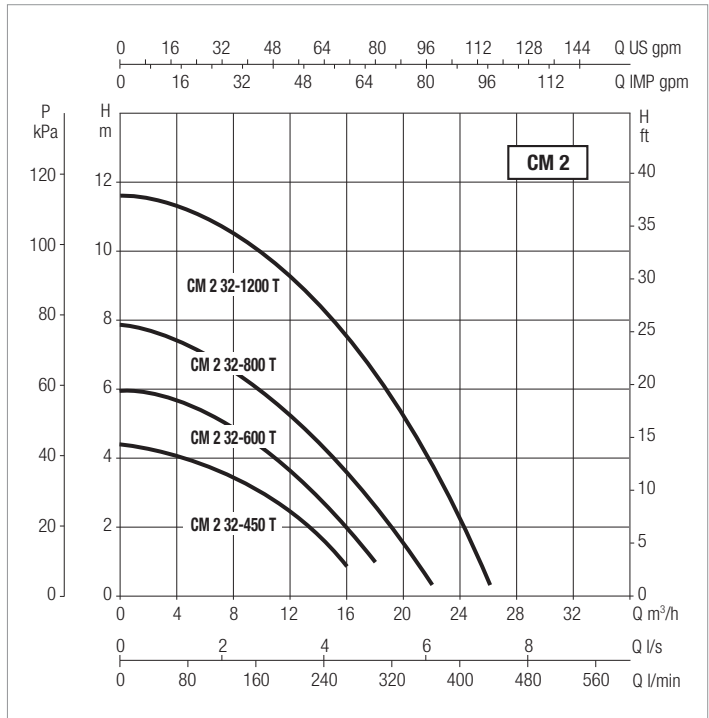
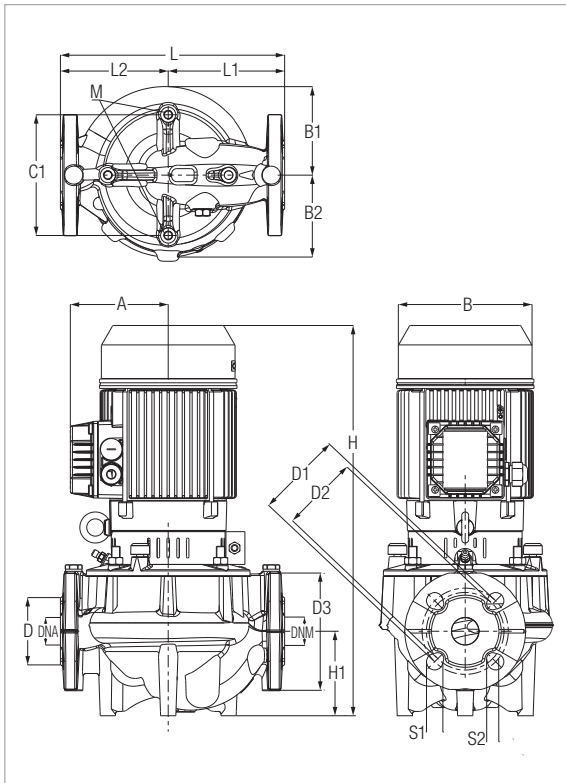

The performance curves are based on kinematic viscosity values = 1 mm<sup>2</sup>/s and density equal to 1000 kg/m<sup>3</sup>. Curve tolerance according to ISO 9906.

MODEL	ELECTRICAL DATA							
	CENTRE DISTANCE	PUMP CONNECTIONS	POWER INPUT 50 HZ	P1 MAX [kW]	P2 NOMINAL		In [Ah]	
					kW	HP	230	400
CM 2 32-450 T	260	DN 32 PN 16 DN 32 PN 10	230-400V	0.25	0,25	0,34	1.2 A	0.7 A
CM 2 32-600 T			230-400V	0.33	0,25	0,34	1.3 A	0.8 A
CM 2 32-800 T	320		230-400V	0.46	0,37	0,50	2.3 A	1.3 A
CM 2 32-1200 T			230-400V	0.77	0,55	0,75	2.6 A	1.5 A

MODEL	A	B	B1	B2	C1	D	D1	S1	D2	S2	D3	DNA	DNM	H	H1	L	L1	L2	M	PACKING DIMENSIONS			VOLUME (mc)	WEIGHT Kg
																				L/A	L/B	H		
																				CM 2 32-450 T	110	150		
CM 2 32-600 T	110	150	102	95	140	78	100	14	90	19	140	32	33	445	98	260	135	125	10	0,53	0,3	0,46	0,07	21,6
CM 2 32-800 T	110	150	129	120	180	80	100	14	90	19	140	32	33	459	90	320	165	155	10	0,52	0,29	0,7	0,11	27
CM 2 32-1200 T	110	150	129	120	180	80	100	14	90	19	140	32	33	459	90	320	165	155	10	0,52	0,29	0,7	0,11	27

## CP 2 - IN-LINE PUMPS FOR CIRCULATION SYSTEMS

Liquid temperature range: from -15°C to +140°C - Maximum operating pressure: 16 bar (1600 kPa)

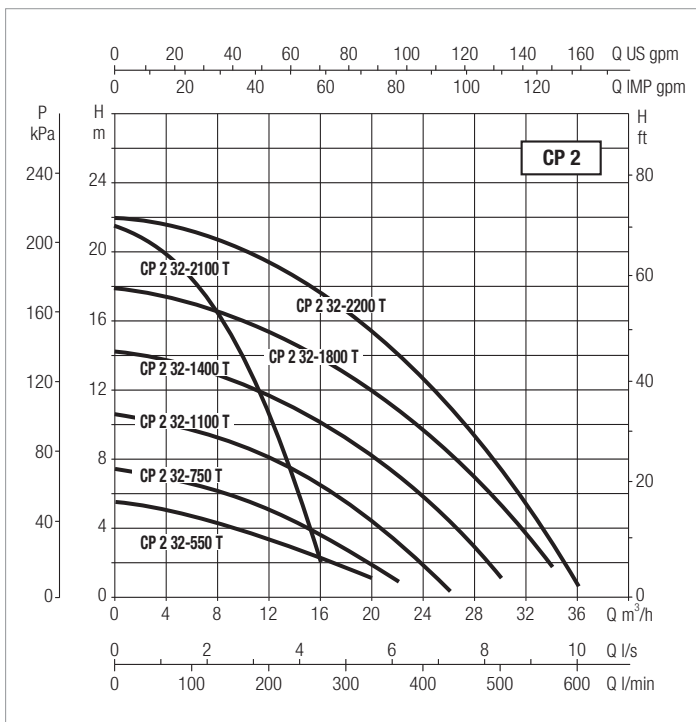
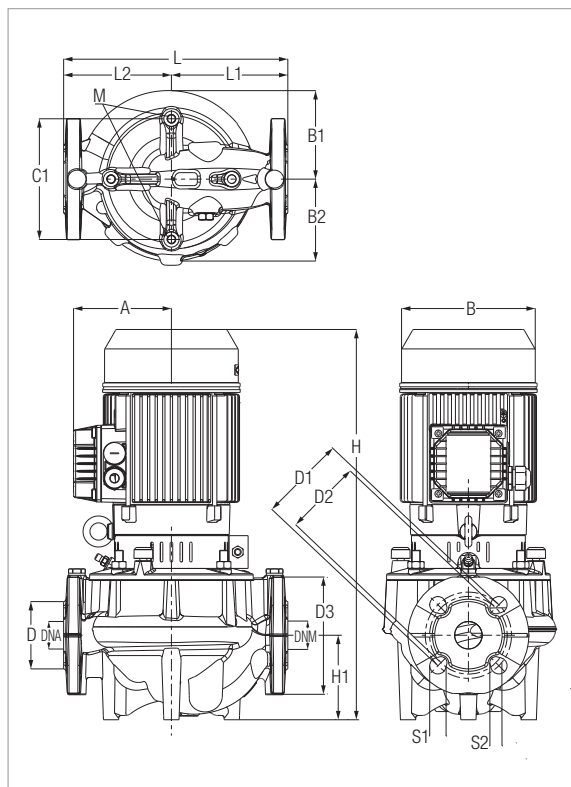

The performance curves are based on kinematic viscosity values = 1 mm<sup>2</sup>/s and density equal to 1000 kg/m<sup>3</sup>. Curve tolerance according to ISO 9906.

MODEL	ELECTRICAL DATA							
	CENTRE DISTANCE	PUMP CONNECTIONS	POWER INPUT 50 HZ	P1 MAX [kW]	P2 NOMINAL		In [Ah]	
					kW	HP	230	400
CP 2 32-550 T	260	DN 32 PN 16 DN 32 PN 10	230-400V	0.36	0,25	0,34	1.7 A	1 A
CP 2 32-750 T			230-400V	0.48	0,37	0,50	1.9 A	1.1 A
CP 2 32-1100 T			230-400V	0.69	0,55	0,75	2.4 A	1.4 A
CP 2 32-1400 T			230-400V	1.07	0,75	1,02	3.5 A	2 A
CP 2 32-1800 T			230-400V	1.48	1,1	1,50	5.6 A	3.2 A
CP 2 32-2200 T			230-400V	1.83	1,5	2,04	6.3 A	3.6 A
CP 2 32-2100 T			230-400V	0.85	0,75	1,02	3 A	1.7 A

MODEL	A	B	B1	B2	C1	D	D1	S1	D2	S2	D3	DNA	DNM	H	H1	L	L1	L2	M	PACKING DIMENSIONS			VOLUME (mc)	WEIGHT Kg
																				L/A	L/B	H		
																				CP 2 32-550 T	110	150		
CP 2 32-750 T	110	150	102	95	140	78	100	14	90	19	140	32	33	445	98	260	135	125	10	0,53	0,3	0,46	0,07	22,6
CP 2 32-1100 T	110	150	102	95	140	78	100	14	90	19	140	32	33	445	98	260	135	125	10	0,53	0,3	0,46	0,07	22,6
CP 2 32-1400 T	110	150	102	95	140	78	100	14	90	19	140	32	33	445	98	260	135	125	10	0,53	0,3	0,46	0,07	24,7
CP 2 32-1800 T	110	150	102	95	140	78	100	14	90	19	140	32	33	445	98	260	135	125	10	0,53	0,3	0,46	0,07	25,5
CP 2 32-2200 T	113	160	102	95	140	78	100	14	90	19	140	32	33	453	98	260	135	125	10	0,53	0,3	0,46	0,07	25
CP 2 32-2100 T	113	160	102	95	140	78	100	14	90	19	140	32	33	453	98	260	135	125	10	0,53	0,3	0,46	0,07	25

## CP 2 - IN-LINE PUMPS FOR CIRCULATION SYSTEMS

Liquid temperature range: from -15°C to +140°C - Maximum operating pressure: 16 bar (1600 kPa)

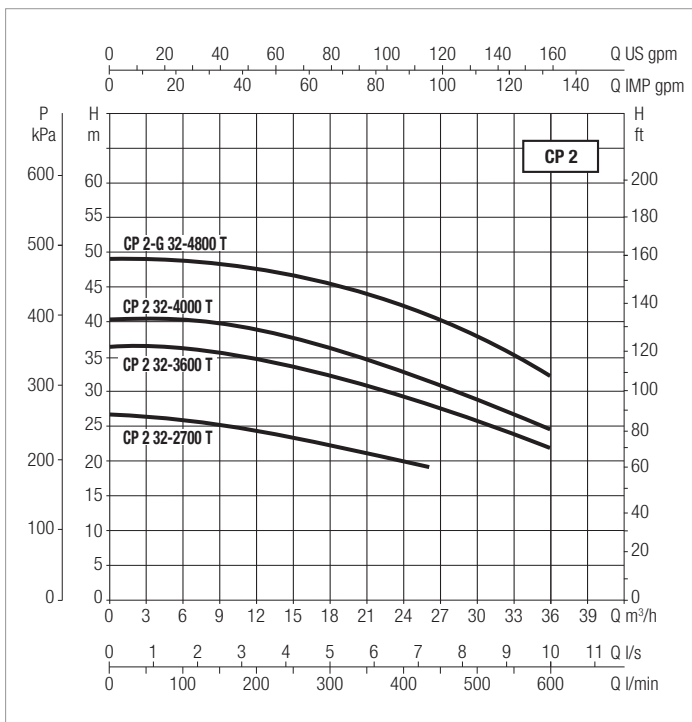
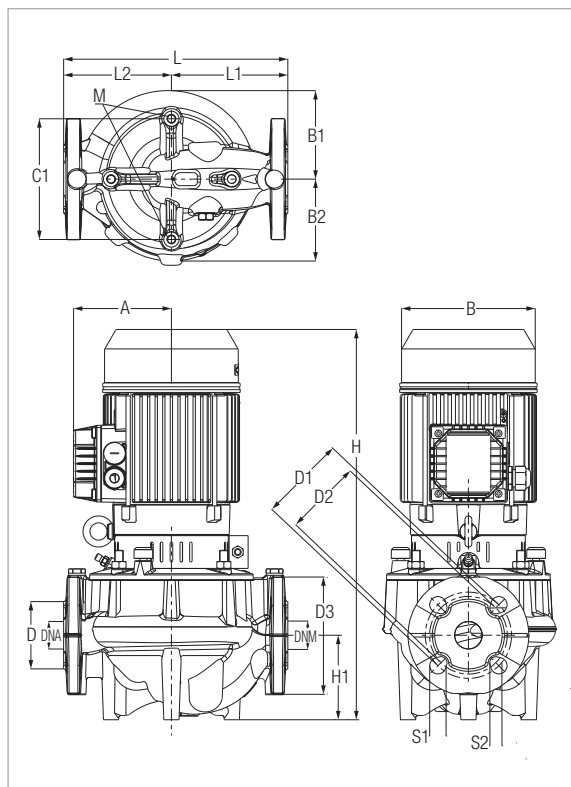

The performance curves are based on kinematic viscosity values = 1 mm<sup>2</sup>/s and density equal to 1000 kg/m<sup>3</sup>. Curve tolerance according to ISO 9906.

MODEL	ELECTRICAL DATA							
	CENTRE DISTANCE	PUMP CONNECTIONS	POWER INPUT 50 HZ	P1 MAX [kW]	P2 NOMINAL		In [Ah]	
					kW	HP	230	400
CP 2 32-2700 T	320	DN 32 PN 16 DN 32 PN 10	230-400V	2.9	2,2	2,99	9 A	5.2 A
CP 2 32-3600 T			230-400V	4.08	3	4,08	12.3 A	7.1 A
CP 2 32-4000 T			230-400V	4.95	4	5,44	15.1	8.7 A
CP 2-G 32-4800 T			230-400V	6.5	5,5	7,48	18.2 A	10.5 A

MODEL	A	B	B1	B2	C1	D	D1	S1	D2	S2	D3	DNA	DNM	H	H1	L	L1	L2	M	PACKING DIMENSIONS			VOLUME (mc)	WEIGHT Kg
																				L/A	L/B	H		
CP 2 32-2700 T	118	160	102	94	140	80	100	14	90	19	140	32	33	526	90	320	165	155	10	0,52	0,29	0,7	0,11	37
CP 2 32-3600 T	135	193	130	125	180	80	100	14	90	19	140	32	33	535	90	320	165	155	10	0,52	0,29	0,7	0,11	45
CP 2 32-4000 T	135	193	130	125	180	80	100	14	90	19	140	32	33	535	90	320	165	155	10	0,52	0,29	0,7	0,11	45
CP 2-G 32-4800 T	202	258	129	120	180	80	100	14	90	19	140	32	33	689	90	320	165	155	10	0,7	0,6	1,1	0,46	74



# DWA

PUMPS SELECTOR

On-line selection tool



**DAB PUMPS LTD.**  
6 Gilbert Court  
Newcomen Way  
Severalls Business Park  
Colchester  
Essex  
CO4 9WN - UK  
salesuk@dwtgroup.com  
Tel. +44 0333 777 5010



**DAB PUMPS IBERICA S.L.**  
Calle Verano 18-20-22  
28850 - Torrejón de Ardoz - Madrid  
Spain  
Info.spain@dwtgroup.com  
Tel. +34 91 6569545  
Fax: + 34 91 6569676



**DAB PUMPS (QINGDAO) CO. LTD.**  
No.40 Kaituo Road, Qingdao Economic & Technological  
Development Zone  
Qingdao City, Shandong Province - China  
PC: 266500  
sales.cn@dwtgroup.com  
Tel. +86 400 186 8280  
Fax +86 53286812210



**DAB PUMPS BV**  
tHofveld 6 C1  
1702 Groot Bijgaarden - Belgium  
info.belgium@dwtgroup.com  
Tel. +32 2 4668353



**DAB PUMPS HUNGARY KFT.**  
H-8800  
Nagykanizsa, Buda Ernő u.5  
Hungary  
Tel. +36 93501700



**DAB PUMPS DE MÉXICO, S.A. DE C.V.**  
Av Amsterdam 101 Local 4  
Col. Hipódromo Condesa,  
Del. Cuauhtémoc CP 06170  
Ciudad de México  
Tel. +52 55 6719 0493



**DAB PUMPS B.V.**  
Albert Einsteinweg, 4  
5151 DL Drunen - Nederland  
info.netherlands@dwtgroup.com  
Tel. +31 416 387280  
Fax +31 416 387299



**DAB PUMPS POLAND Sp. z o.o.**  
Ul. Janka Muzykanta 60  
02-188 Warszawa - Poland  
polska@dabpumps.com.pl



**DAB PUMPS OCEANIA PTY LTD**  
426 South Gippsland Hwy,  
Dandenong South VIC 3175 - Australia  
info.oceania@dwtgroup.com  
Tel. +61 1300 378 677



**DAB PUMPS INC.**  
3226 Benchmark Drive  
Ladson, SC 29456 - USA  
info.usa@dwtgroup.com  
Tel. 1- 843-797-5002  
Fax 1-843-797-3366



**PT DAB PUMPS INDONESIA**  
Satrio Tower lantai 26  
unit C-D, Jl. Prof. Dr. Satrio Kav. C4,  
Kel. Kuningan Timur, Kec. Setiabudi, Kota Adm.  
Jakarta Selatan, Prov. DKI Jakarta. - Indonesia  
Tel. +62 2129222850



**DAB PUMPS GMBH**  
Am Nordpark 3  
D - 41069 Mönchengladbach - Germany  
info.germany@dwtgroup.com  
Tel. +49 2161 47388-0  
Fax +49 2161 47388-36



**DAB PUMPS SOUTH AFRICA (PTY) LTD**  
Twenty One industrial Estate,  
16 Purlin Street, Unit B, Warehouse 4  
Olifantsfontein -1666 - South Africa  
info.sa@dwtgroup.com  
Tel. +27 12 361 3997